



## **NIKKEN Innovation Centre Europe**

Advanced Manufacturing Park, Brindley Way,  
Catcliffe, Rotherham, S60 5FS, UK

**t:** +44 (0)1709 366306 | **f:** +44 (0)1709 376683

**e:** [info@nikken-world.com](mailto:info@nikken-world.com) | **w:** [www.nikken-world.com](http://www.nikken-world.com)



*The Spirit of Innovation*

## High Precision Sleeve

Our range of High Precision Sleeves for sliding head automatic turning machines allow customers to benefit from Nikken's innovative tooling features such as our patented TiN Bearing Nut - to ensure the cutting tool is securely clamped without distortion thus maintaining the optimum accuracy and performance.

These are ideally suited to high precision drilling and reaming operations and are available in both Slim Chuck (SK) and Mini-Mini Chuck (MMC) forms.



Code No.	Chucking Dia.
SK6 - 0.8	0.7 ~ 0.8
- 1	0.9 ~ 1.0
- 1.25	1.15 ~ 1.25
- 1.5	1.3 ~ 1.5
- 1.75	1.55 ~ 1.75
- 2	1.8 ~ 2.0
- 2.25	2.05 ~ 2.25
- 2.5	2.3 ~ 2.5
- 2.75	2.55 ~ 2.75
- 3	2.8 ~ 3.0
- 3.5	3.0 ~ 3.5
- 4	3.5 ~ 4.0
- 4.5	4.0 ~ 4.5
- 5	4.5 ~ 5.0
- 5.5	5.0 ~ 5.5
- 6	5.5 ~ 6.0

Code No.	Chucking Dia.
SK10 - 2	1.75 ~ 2.0
- 2.25	2.0 ~ 2.25
- 2.5	2.25 ~ 2.5
- 2.75	2.5 ~ 2.75
- 3	2.75 ~ 3.0
- 3.5	3.0 ~ 3.5
- 4	3.5 ~ 4.0
- 4.5	4.0 ~ 4.5
- 5	4.5 ~ 5.0
- 5.5	5.0 ~ 5.5
- 6	5.5 ~ 6.0
- 6.5	6.0 ~ 6.5
- 7	6.5 ~ 7.0
- 7.5	7.0 ~ 7.5
- 8	7.5 ~ 8.0
- 8.5	8.0 ~ 8.5
- 9	8.5 ~ 9.0
- 9.5	9.0 ~ 9.5
- 10	9.5 ~ 10.0



Wrench for SK Sleeve  
SKL-6W & SKL-10

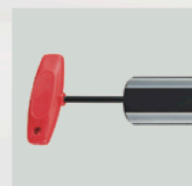

Clamping tool for MMC Sleeve  
EA573KL-6

### SK Sleeve (Slim Chuck)

Code No.	Tool Shank Dia. DCON	t	Chucking Dia. DCONN-DCONX	Total Length OAL	Stem Length LTA	Nut Dia. DLN	Adjustable Range LSCN-LSCX	G NO. (Optional)	Weight (kg)	Collet	Wrench (Optional)
ST3/4(20) -SK 6- 81	19.05(20)	9	0.7 ~ 6.0	80.5	20.5	19.5	21 - 35	SKG-8	0.14	SK6	SKL-6W (SKL-6WS)
ST3/4(20) -SK 6-141				140.5					0.26		
ST3/4CM-SK 6- 97				96.5					0.17		
ST1(25) -SK10- 82	25.4(25)	11	1.75 ~ 10.0	82.1	22.1	27.5	30 - 57	SKG-12L	0.23	SK10	SKL-10
ST1(25) -SK10-142				142.1					0.40		
ST1CM -SK10- 97				25.4					97.1		

### MMC Sleeve (Mini Mini Chuck)

Code No.	Tool Shank Dia. DCON	t	Chucking Dia. DCONN-DCONX	Total Length OAL	Adjustable Range LSCN-LSCX	Collet	Wrench (Optional)
K5/8CM-MMC4- 50	15.875	7	1.0 ~ 4.0	52.0	16 ~ 24	MPK4	Hex 4mm
K3/4CM-MMC8- 80	19.05	9	1.8 ~ 8.0	81.5	22 ~ 41	PMK8	Hex 8mm or EA573KL-6
K20CM -MMC8-100	20.0			101.5			
K1CM -MMC8-100	25.4	11		101.5			

**NIKKEN**

# Zero HOLDER OLEZ

**& High Precision Sleeve**



**Ultra Deep Drilling & Precise Reaming  
for Turning Machines**

# Ultra Deep Drilling & Precise Reaming for Turning Machines

## ■ Zero-Zero Holder

Our NEW 'Zero-Zero' holder for turning machines is designed for extended length processes and cutting tools. The innovative design provides adjustment technically in two planes. Firstly adjustment of the cutting tool run-out is applied using our 'Zero-Fit' cam system and then physical misalignment from centre can also be adjusted radially. The simple two-step procedure ensures that the cutting edges are corrected to their most effective and correct position eliminating errors and improving performance.

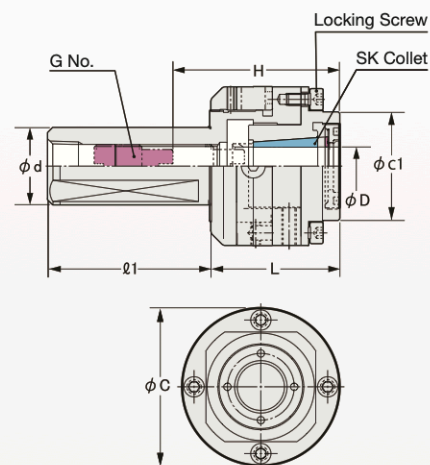

Code No.	D	d	L	$\ell_1$	H	C	c1	G NO. (Optional)	SK Collet (Optional)	Spanner (Optional)
LCH32-SZF16S-55	2.75-16	32	54.3	68	70	66	45	SKG-18L	SK-16	SKL-16S-P
LCH40-SZF16S-55		40								

Radial screw to adjust axial misalignment

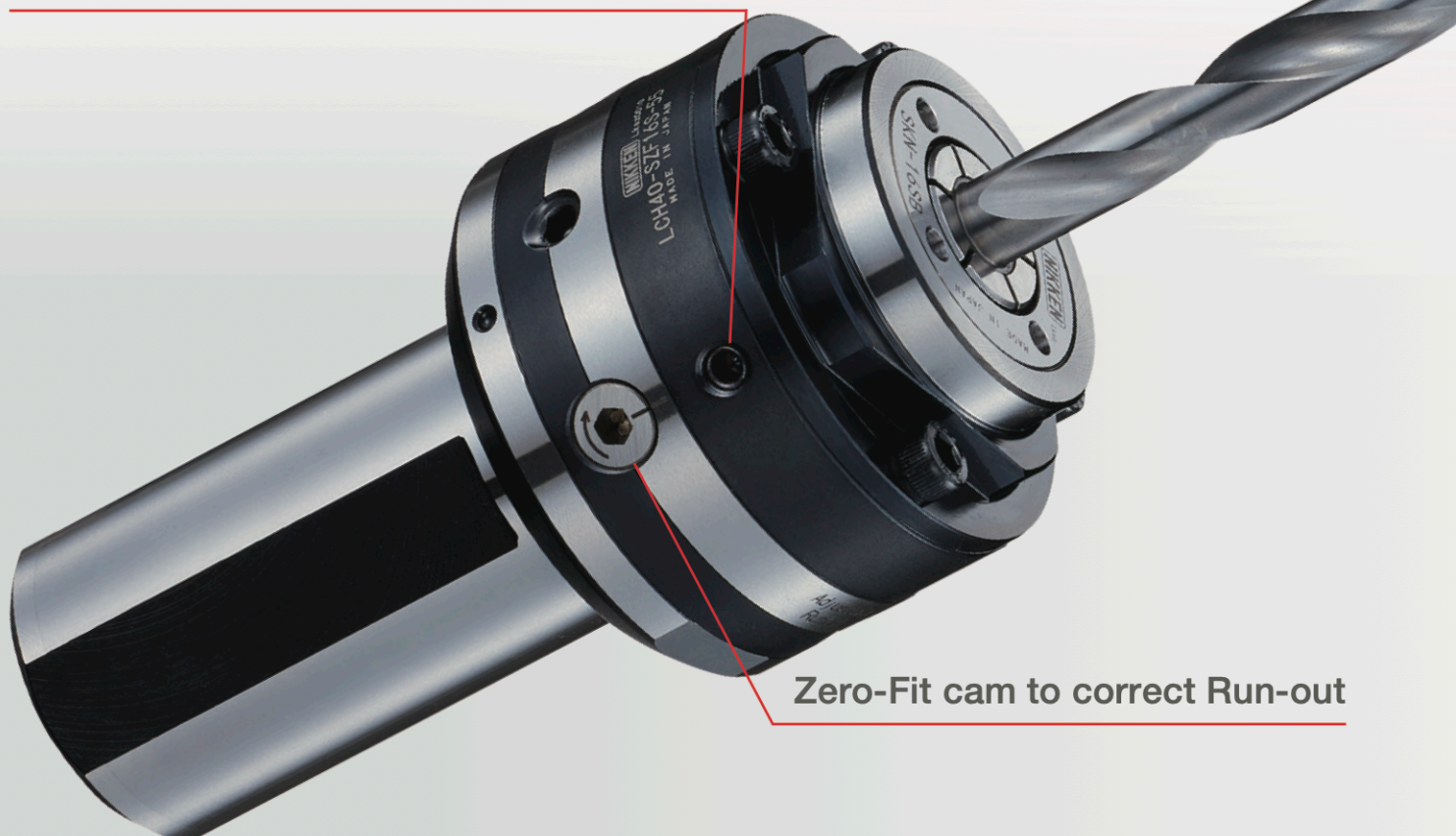

# Runout accuracy and the impact for tool life and part quality

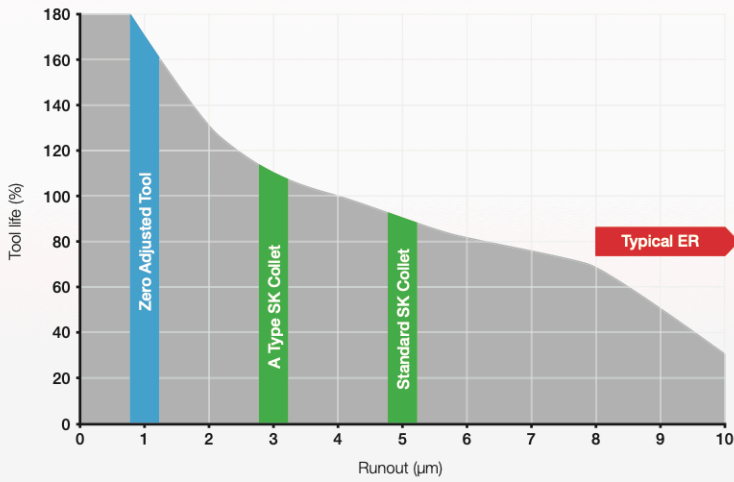

Taken from 'Metal Cutting Theory and Practice' 3rd Edition

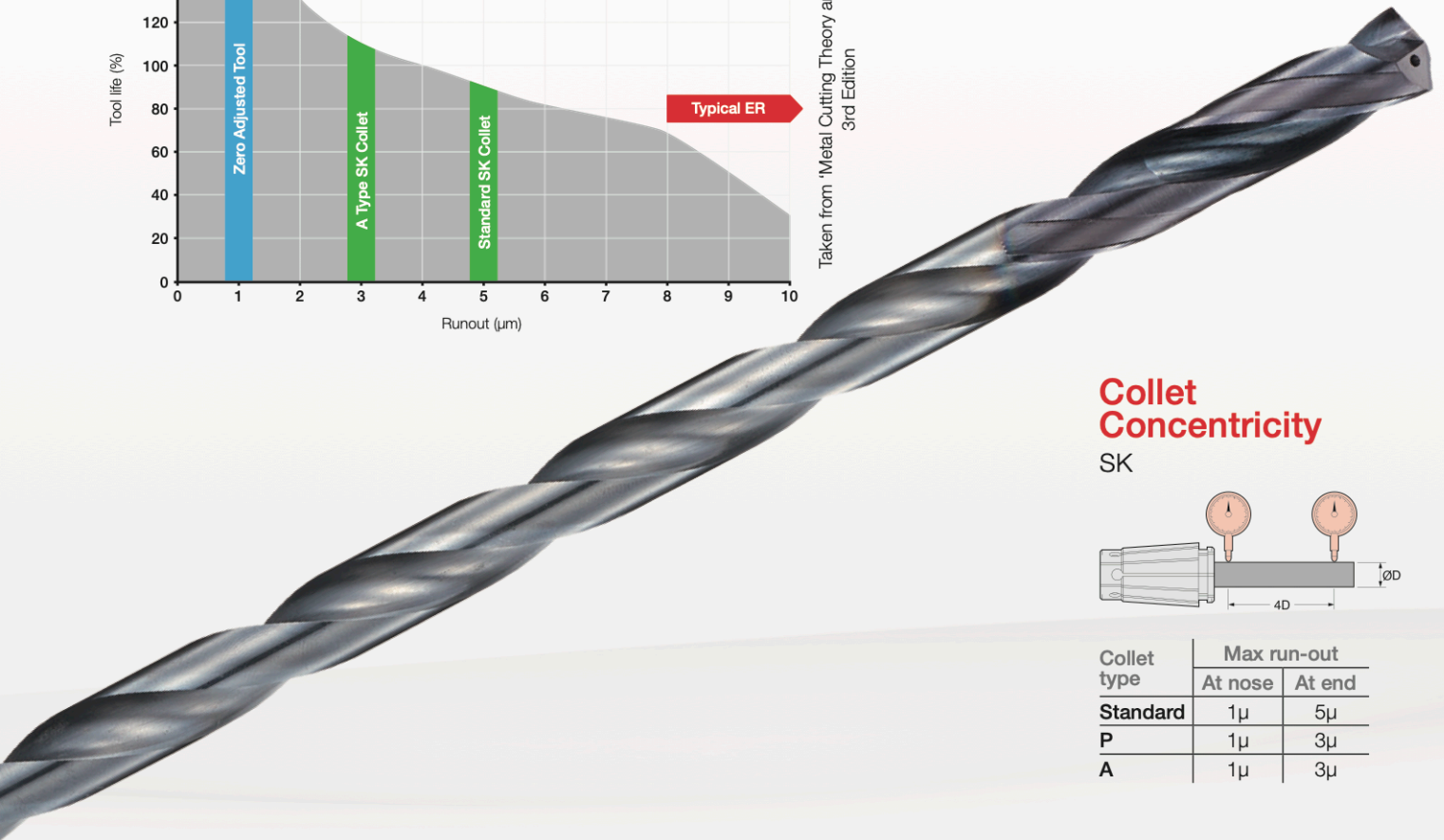

## Collet Concentricity

SK

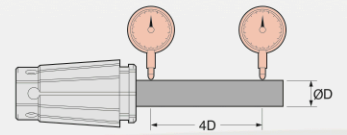

Collet type	Max run-out	
	At nose	At end
Standard	1µ	5µ
P	1µ	3µ
A	1µ	3µ

## Accessories



Adjustment Wrench 9ZFL



Tightening Spanner SKL-16S-P



Dial Gauge LCD



Internal SK Nuts SKN-16SB SKN-16SB-9L

## Run-out Adjustment

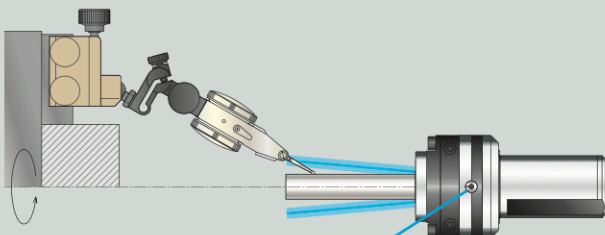

Cam to adjust run-out of the cutting edge

## Misalignment Adjustment

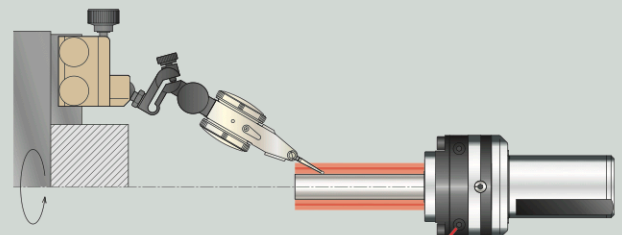



Screw to adjust misalignment of the spindle center



## SK Collets & SK Coolant Collets

A perfect seal, ideal for coolant trough tools



D	Standard Type	for Drilling	for Endmill	for Coolant-thru Tools
	SK Collet	P-class Collet	A-type Collet	SK Coolant Collet
2.75 ~ 3.0	SK16 - 3	SK16 - 3P	SK16 - 3A	
3.0 ~ 3.5	- 3.5	- 3.5P		
3.5 ~ 4.0	- 4	- 4P	- 4A	
4.0 ~ 4.5	- 4.5	- 4.5P		
4.5 ~ 5.0	- 5	- 5P	- 5A	
5.0 ~ 5.5	- 5.5	- 5.5P		
5.5 ~ 6.0	- 6	- 6P	- 6A	
6.0 ~ 6.5	- 6.5	- 6.5P		
6.5 ~ 7.0	- 7	- 7P		
7.0 ~ 7.5	- 7.5	- 7.5P		
7.5 ~ 8.0	- 8	- 8P	- 8A	SK16 - 8AC
8.0 ~ 8.5	- 8.5	- 8.5P		
8.5 ~ 9.0	- 9	- 9P		
9.0 ~ 9.5	- 9.5	- 9.5P		
9.5 ~ 10.0	- 10	- 10P	- 10A	- 10AC
10.0 ~ 10.5	- 10.5	- 10.5P		
10.5 ~ 11.0	- 11	- 11P		
11.0 ~ 11.5	- 11.5	- 11.5P		
11.5 ~ 12.0	- 12	- 12P	- 12A	- 12AC
12.0 ~ 12.5	- 12.5	- 12.5P		
12.5 ~ 13.0	- 13	- 13P		
13.0 ~ 13.5	- 13.5	- 13.5P		
13.5 ~ 14.0	- 14	- 14P		
14.0 ~ 14.5	- 14.5	- 14.5P		
14.5 ~ 15.0	- 15	- 15P		
15.0 ~ 15.5	- 15.5	- 15.5P		
15.5 ~ 16.0	- 16	- 16P	- 16A	- 16AC
Nut	SKN-16SB		SKN-15SB-9L (Optional)	
Tightening Spanner	SKL-16S-P (Optional)	